

AMPHORA

Assembly Instructions AMPHORA Ready

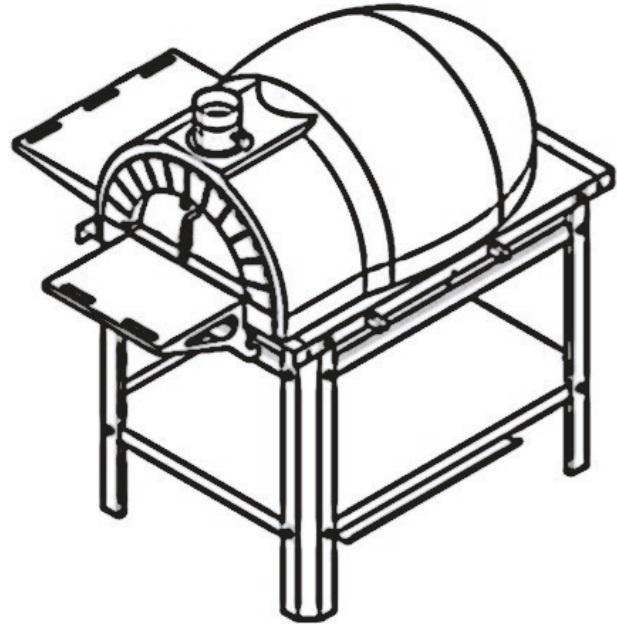

Warning

The glazing is very fragile and the edges are prone to damage during the transport or assembling.

When working with the shaped pieces of the body, proceed very carefully, do not use excessive force.

If a light damage occurs, you can use the supplied silicone caulk or any nail-polish with similar colour to repaint the discrepancy.

Process

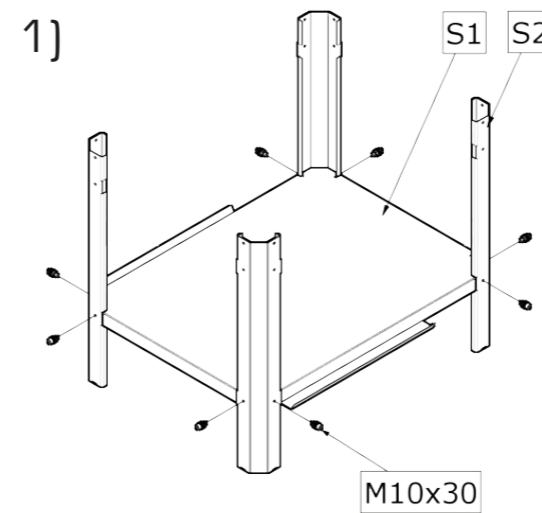

Bolt the bottom plate to the stand legs. Do not tighten the joints. In case the a screw doesn't easily fit into a hole, make the hole wider with a file. Paint over the altered surface with a paint for metal.

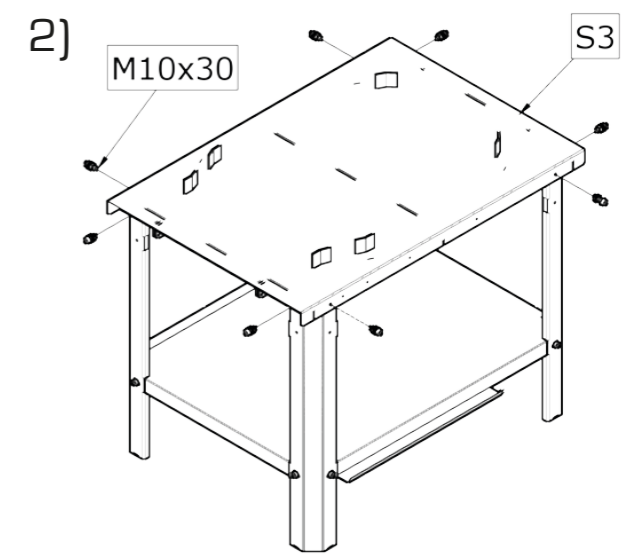

Screw stand legs to the top plate. Do not tighten the joints.

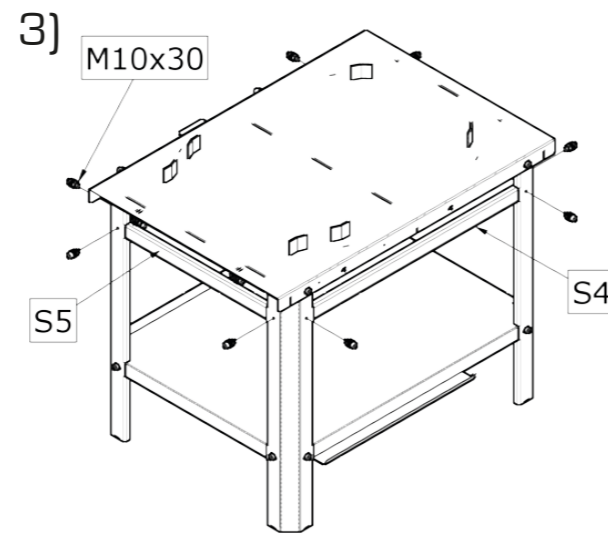

Bolt partitions between individual legs (direct the bends inwards). Tighten all the already applied bolted joints.

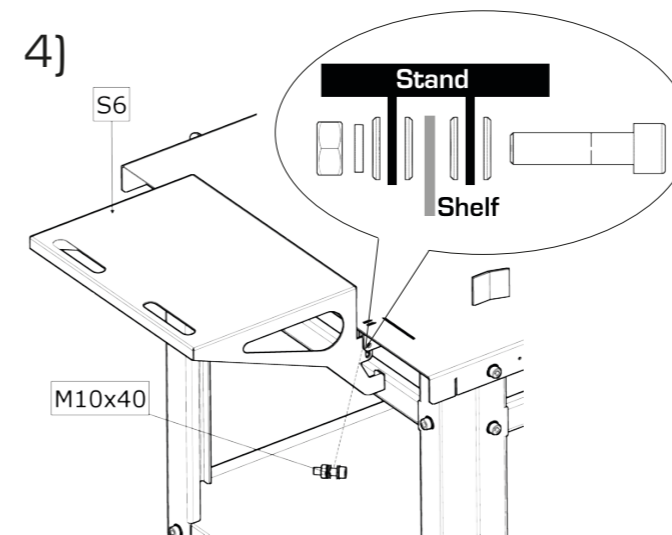

Insert the front shelf into the grooves and bolt it on both sides. Do not tighten the joints too much, movement of the shelf in the grooves needs to be secured so that it can tilt.

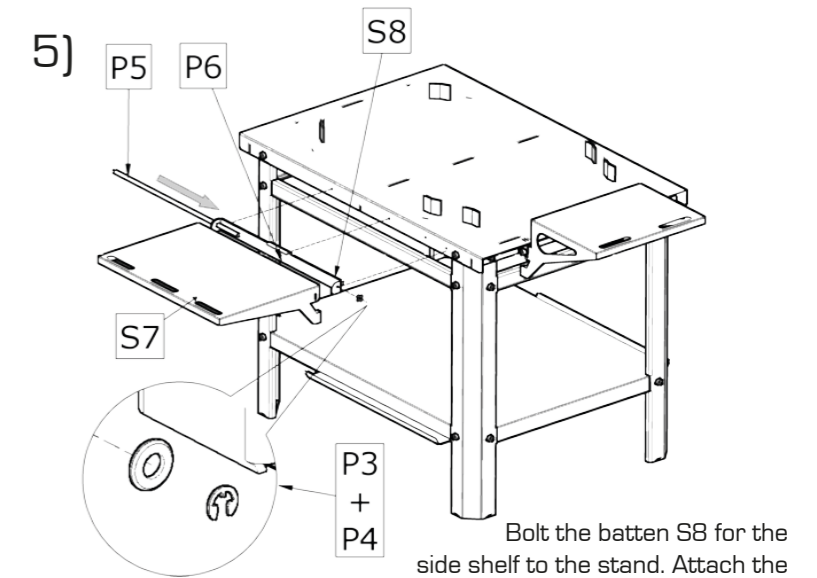

Bolt the batten S8 for the side shelf to the stand. Attach the shelf to the batten by pulling the axis through and securing it on both sides against slipping out by washers and lock rings. The side to which the side shelf is to be mounted may be selected as necessary.

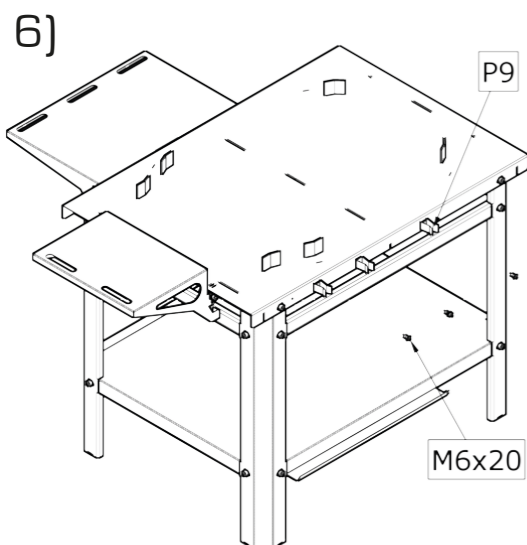

Bolt the holders for accessories to the opposite side to the side shelf.

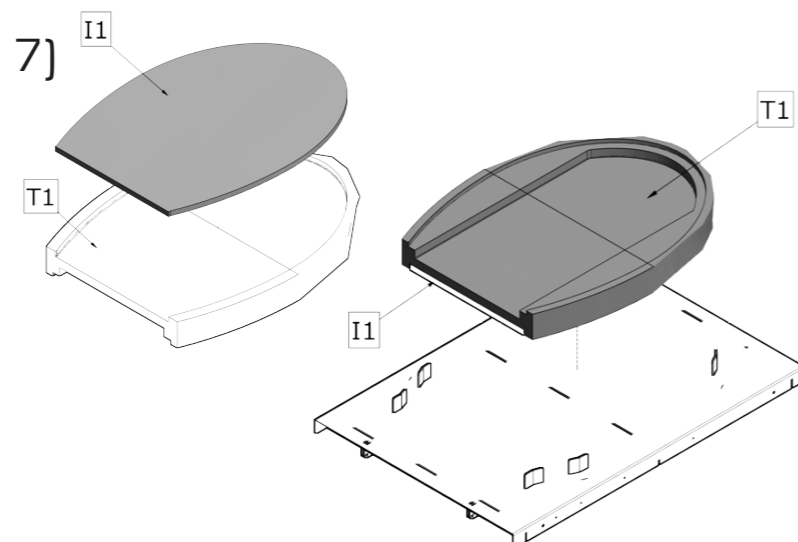

Using a bonding agent, glue the bio-mat (part I1 rear bottom according to the cutting plan of the bio-mat) to the bottom cutout of the bottom rear plate, place the plate by this bottom side with the bio-mat to a stand.

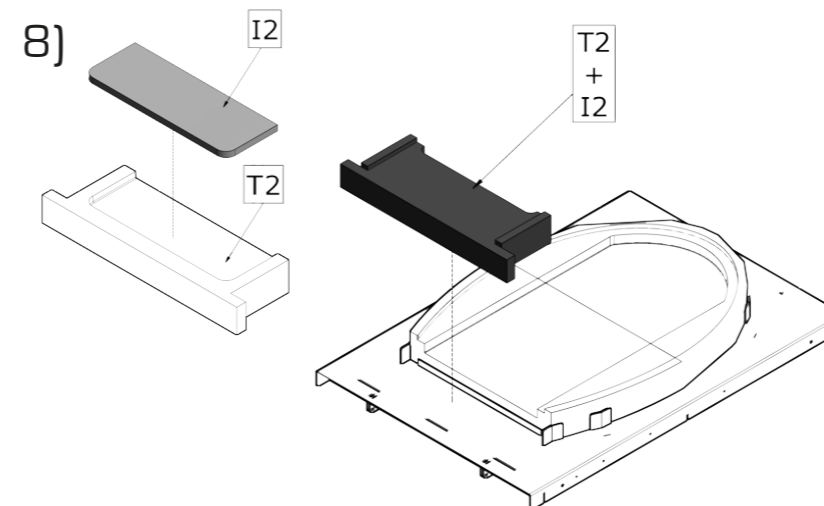

Using a bonding agent, glue the bio-mat (part I2 front bottom according to the cutting plan of the bio-mat) into the bottom cutout of the bottom front plate, place the plate by this bottom side with the bio-mat to the stand.

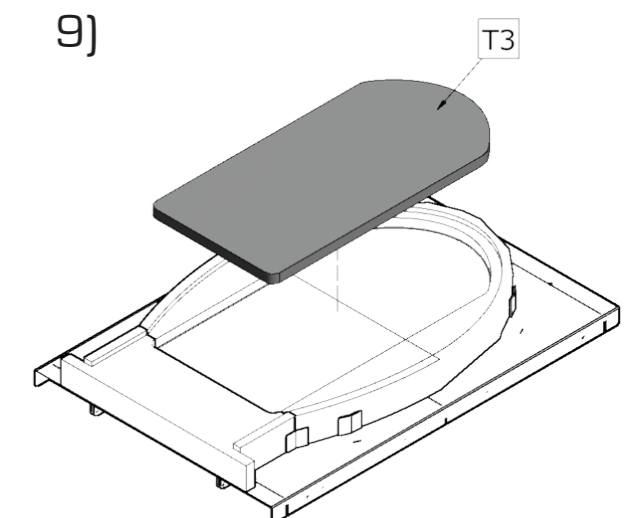

Place the inner plate into the bottom plate cutout.

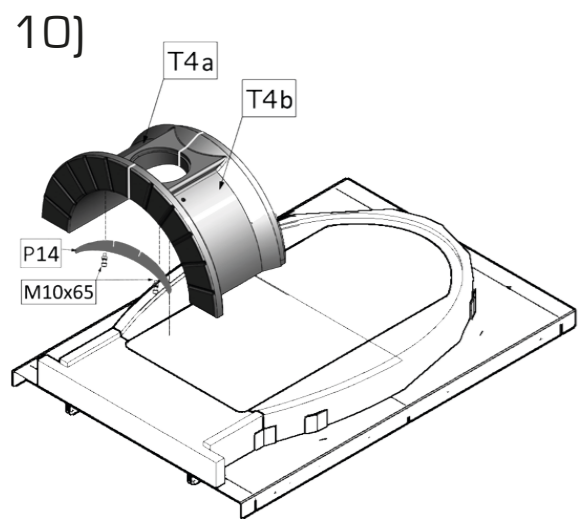

Place the front arch on the front plate of the bottom. Then bolt the smoke guard to the arch. Do not tighten the joints too firmly, otherwise the damage of the refractory shapes may occur due to heat dilatation.



Place the rear arch on the rear plate of the bottom.

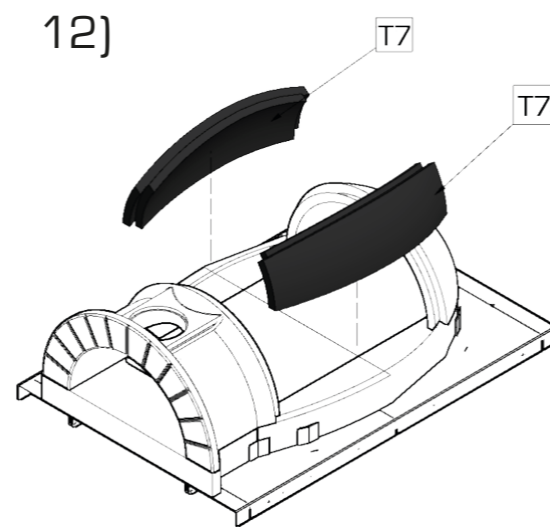

Place the small side arch between the front and rear arch. Side arches should be placed with a hole towards the front portal.

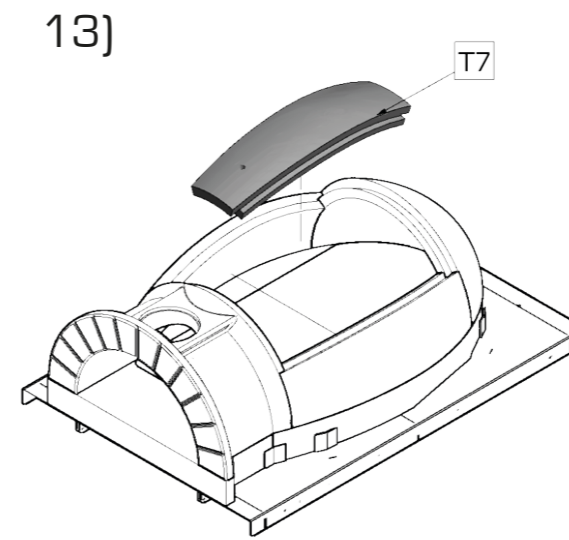

Place the central part of the arch with a hole towards the chimney. Shape should be placed on the top of the arch.

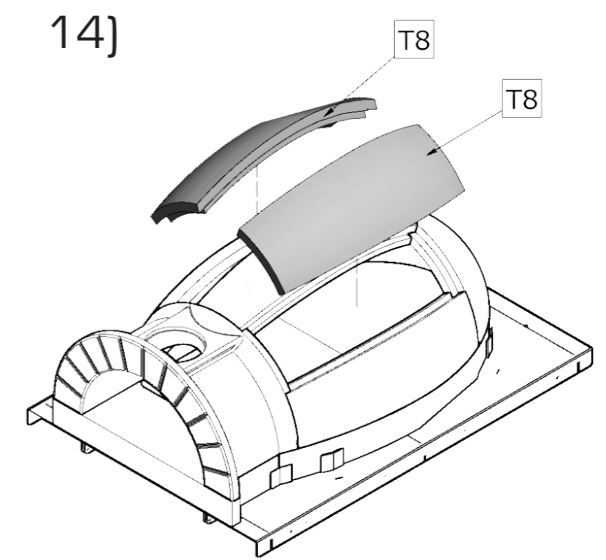

Place the last two shaped pieces into the remaining space so that the locks match.

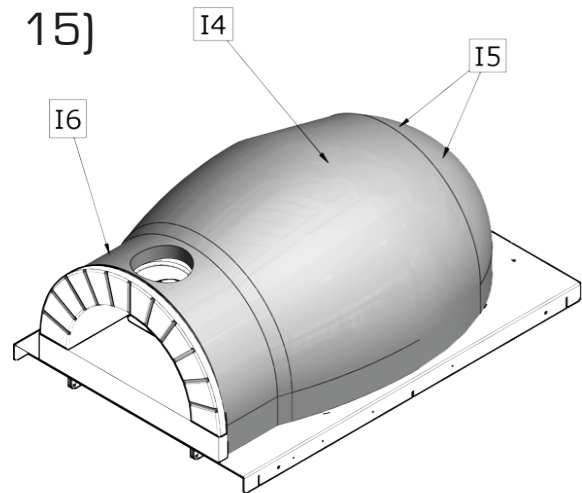

Cover the assembled arch with at least 1 layer of aluminium foil I8. Place the isolation bio-mat on the aluminium foil according to the cutting plan for the bio-mat. Make sure the bio-mat doesn't get distorted during the application.

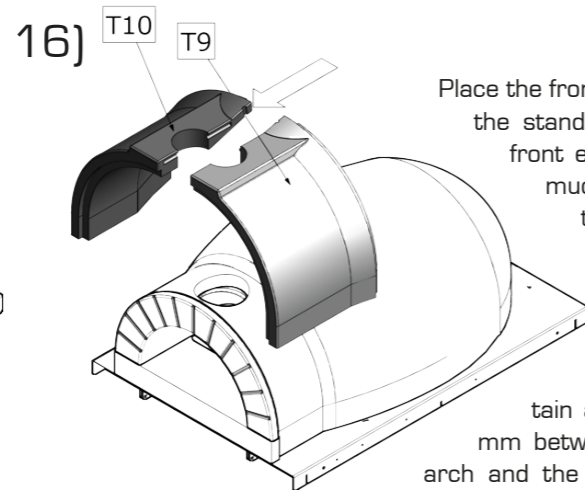

Place the front parts T9 and T10 of the body to the stand above the front arch (push the front edge of the body to the portal as much as possible). Before you connect the two parts, apply adequate amount of silicone caulk into the locks and on the whole surface between the parts. Make sure the caulk don't fill a hole for the thermometer. Maintain a dilatational interstice at least 3 mm between the upper edge of the front arch and the front part of the body. For this purpose place the supplied dilatation pads under the side edges. If you use more than 2 pieces of pads on top of each other, bind them together using silicone caulk. (A purpose of the silicone caulk application between the two front parts is to connect them so that they don't spread and also as a protection against water if you don't follow the warranty conditions to place the oven under a roof.)

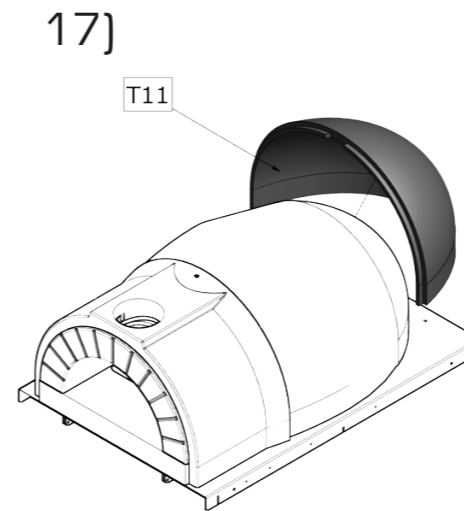

Place the rear body to the stand above the rear arch.

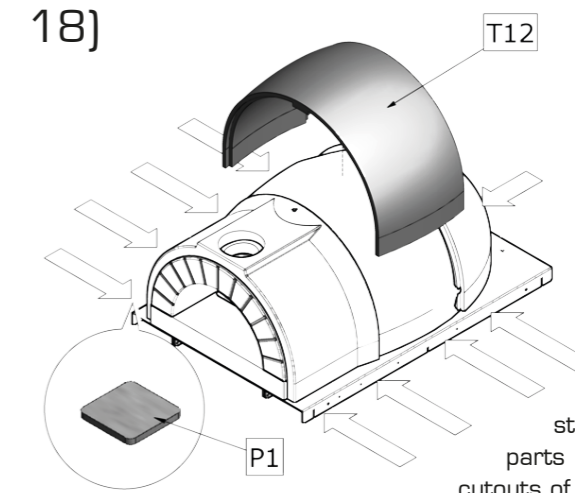

Place the central part of the body on the stand between individual parts of the body so that the cutouts of individual shaped pieces match and joints are as narrow as possible. If it is necessary to align the parts, place the supplied dilatation pads under the side edges, preferably at places marked by arrows (9 points). Do not remove the pads. If you use more than 2 pieces of pads on top of each other, bind them together using silicone caulk.

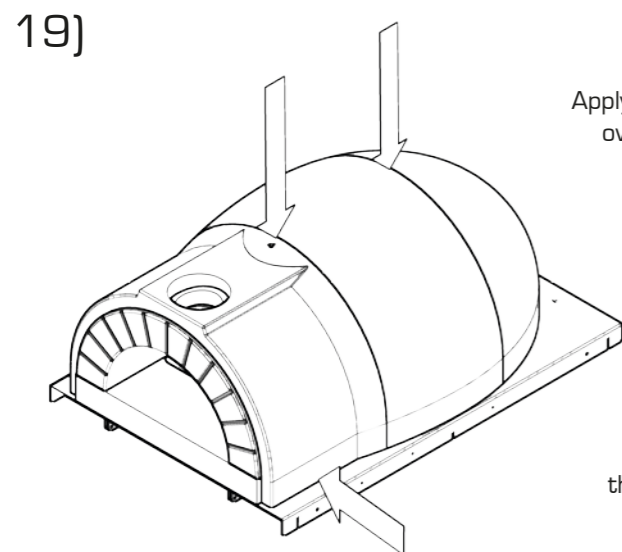

Apply silicone caulk between the body parts and along oven circumference between the bottom edge of the body and the stand - into the formed joint, the used dilatation pads should also get fixed. Silicone the chinks in the way the silicone caulk could be removed in the case of necessity of disassembling the oven (e.g. in the case of a warranty claim).

A purpose of this silicone caulk application is to prevent water to get into the oven in the case you don't follow the warranty conditions to place the oven under a roof. If you follow the conditions, it's enough to fix the dilatation pads.

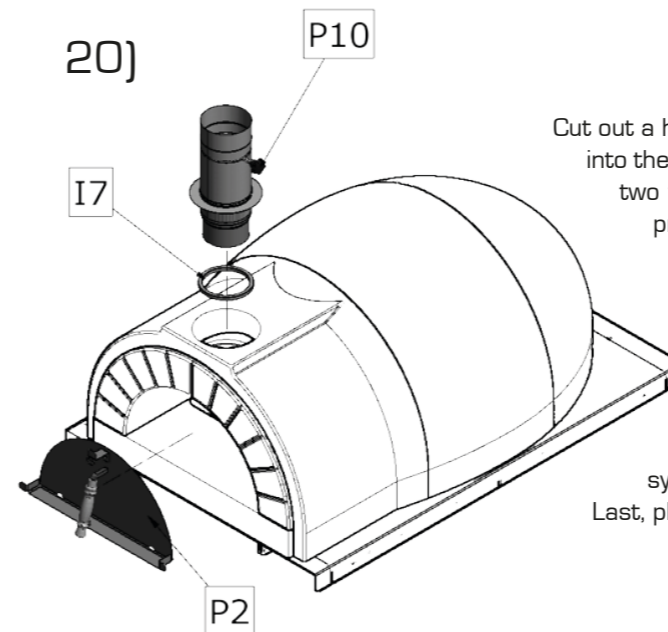

Cut out a hole for the chimney (through insulation and the aluminium foil). Place the rope seal into the opening in the front body into the prepared groove in the inner front arch to create two threads of rope seal. Insert carefully the chimney base until the cover flange sits properly on the oven body. You can check with your hand from inside of the chimney if the rope doesn't get distorted while inserting the chimney base (if the rope gets damaged, heat and smoke can get into the space between the inner shapes and the body). Turn the dumper always lightly, not more than 90 degrees. Otherwise the thread may turn and the sign "open, closed" may not correspond with an actual position. Preferably don't pull out the chimney base out of the oven very often otherwise the rope seal may get damaged. When attaching chimney which is longer than half a meter, make sure that chimney system is not exerting excessive pressure on the body. Close the oven with steel door. Last, place the thermometer into the opening behind the chimney (for proper mounting it is necessary to pierce through the insulation).

LIST OF SUPPLIED PARTS - AMPHORA Ready

Refractory shapes

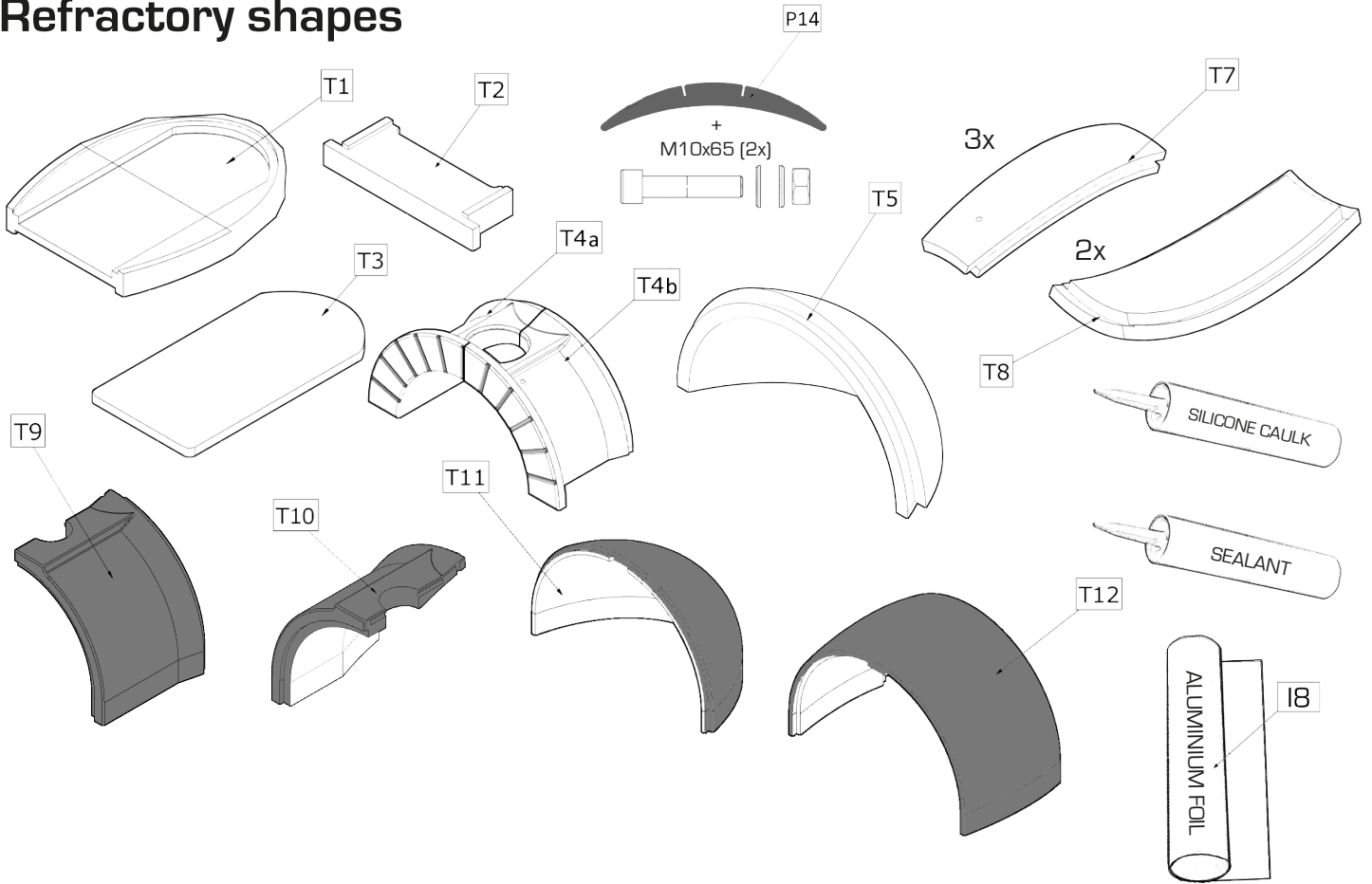

Cutting plan of the bio-mat

Part I1 Rear bottom

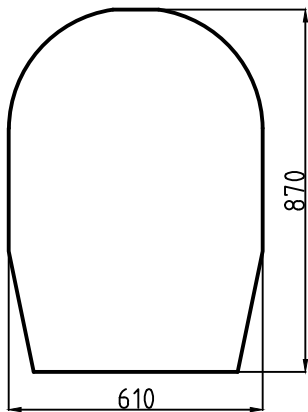

Part I6 Front body

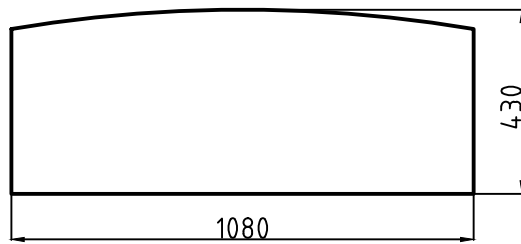

Part I4 Central body

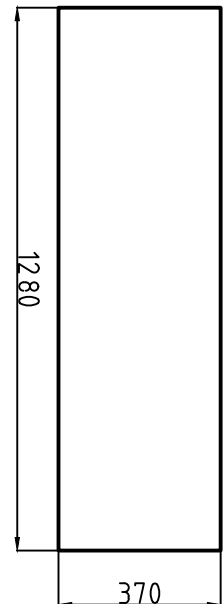

Part I2 Front bottom

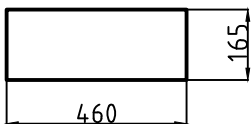

Parts I5 Rear body 1 and 2

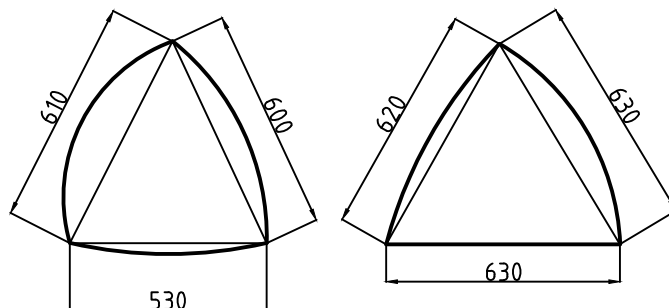

Stand & Accessories

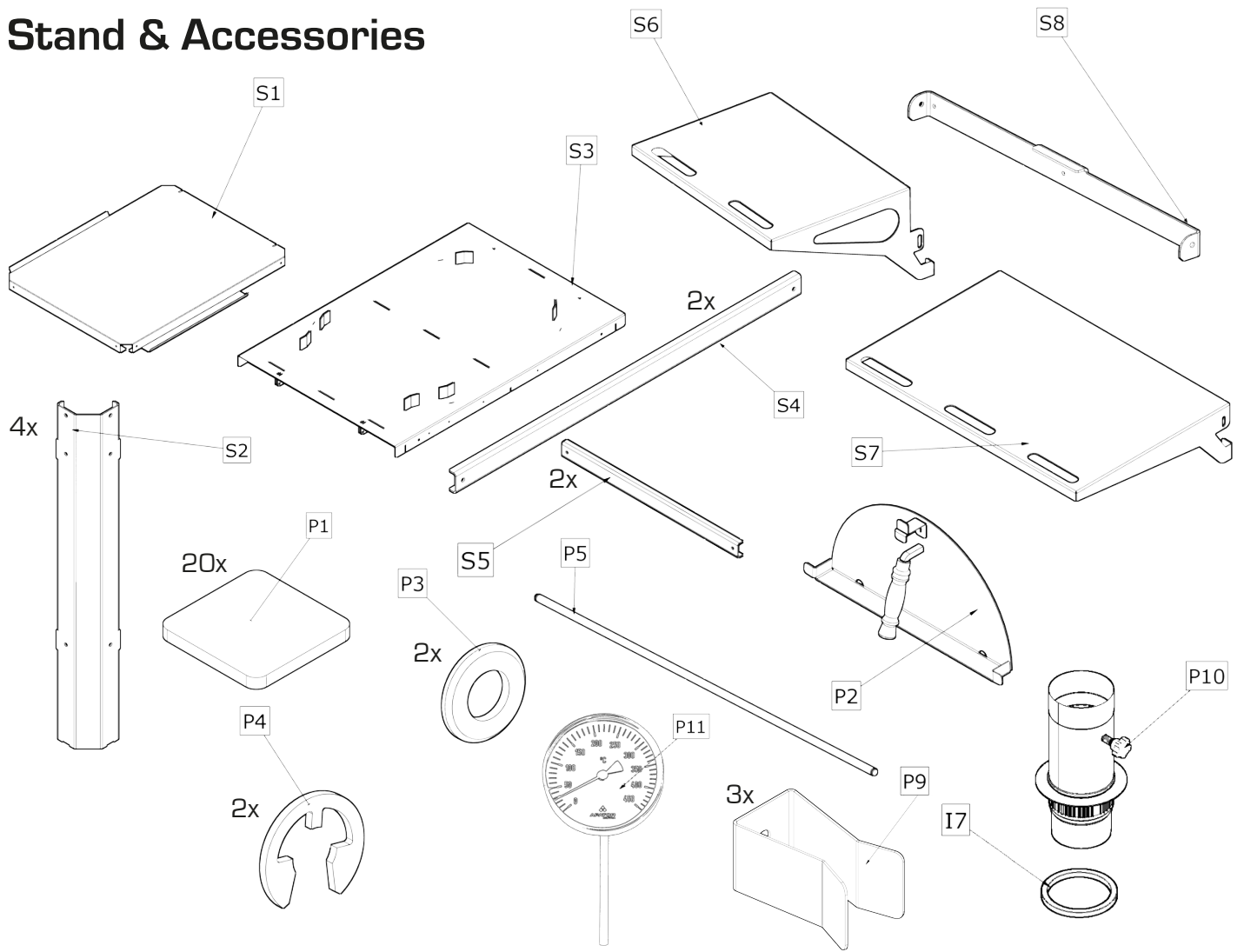

Bolted joints

M6x20 (3x)

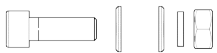

- 1x Socket cap screw M6x20
- 2x KR 6 Washer
- 1x KR 6 Spring washer
- 1x M6 Hexagon nut

M10x30 (24x)

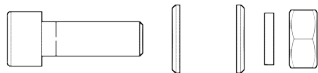

- 1x Socket cap screw M10x30
- 2x KR 10 Washer
- 1x KR 10 Spring washer
- 1x M10 Hexagon nut

M10x40 (2x)

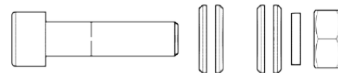

- 1x Socket cap screw M10x40
- 4x KR 10 Washer
- 1x KR 10 Spring washer
- 1x M10 Hexagon nut

P6 - M6x20 - Countersink (3x)



- 1x Countersink screw M6x20
- 2x KR 6 Washer
- 1x KR 6 Spring washer
- 1x M6 Hexagon nut